



MATH ASSESSMENT PROGRAM





Student Name _____

P



**Grade 5
Mathematics
Test Booklet**

Practice Test

TEST BOOKLET SECURITY BARCODE

Section 1

(Non-Calculator)

Directions:

Today, you will take Section 1 of the Grade 5 Mathematics Practice Test. You will not be able to use a calculator.

Read each question. Then, follow the directions to answer each question. Mark your answers by completely filling in the circles in your answer document. Do not make any pencil marks outside of the circles. If you need to change an answer, be sure to erase your first answer completely. If a question asks you to show or explain your work, you must do so to receive full credit. Only responses entered within the space provided will be scored.

If you do not know the answer to a question, you may go on to the next question. If you finish early, you may review your answers and any questions you did not answer in this section ONLY. Do not go past the stop sign.

- 1 The following figure is made up of two rectangular prisms with the same width of 5 centimeters. Other dimensions of the prisms are given in centimeters.

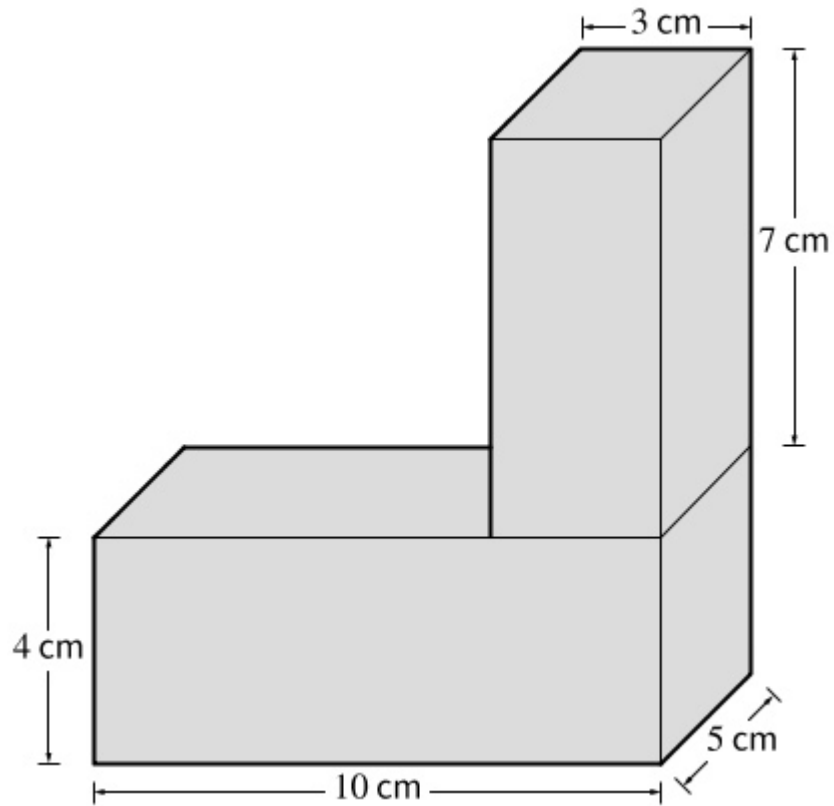

What is the volume, in cubic centimeters, of the figure?

Enter your answer in the space provided.

2 What is the value of $\frac{5}{7} - \frac{1}{3}$?

A $\frac{4}{21}$

B $\frac{8}{21}$

C $\frac{4}{7}$

D $\frac{4}{4}$

3 A number is shown in expanded form.

$$3 \times 10 + 6 \times 1 + 8 \times \frac{1}{1,000}$$

What is this number in standard form?

Enter your answer in the space provided.

4 Tom travels $3\frac{2}{3}$ miles to school every day. Sara travels $\frac{3}{5}$ of Tom's distance.

How many miles does Sara travel to school?

A $2\frac{1}{5}$

B $3\frac{1}{15}$

C $3\frac{2}{5}$

D $6\frac{1}{9}$

5 What is the remainder when 3,235 is divided by 20?

Enter your answer in the space provided.

6 Which **two** equations are correct?

Select the **two** correct answers.

A $\frac{1}{5} \div 4 = \frac{4}{5}$

B $\frac{1}{6} \div 2 = \frac{1}{3}$

C $\frac{1}{8} \div 3 = \frac{1}{24}$

D $\frac{1}{10} \div 4 = \frac{5}{2}$

E $\frac{1}{16} \div 2 = \frac{1}{32}$

7 Which table shows expressions that represent these phrases?

- 8 more than the product of 5 and 7
- 5 times the sum of 7 and 8

Select one answer.

A

8 more than the product of 5 and 7	5 times the sum of 7 and 8
$(8 + 5) \times 7$	$5 \times 7 + 8$

B

8 more than the product of 5 and 7	5 times the sum of 7 and 8
$8 + 5 \times 7$	$5 \times 7 + 8$

C

8 more than the product of 5 and 7	5 times the sum of 7 and 8
$(8 + 5) \times 7$	$5 \times (7 + 8)$

D

8 more than the product of 5 and 7	5 times the sum of 7 and 8
$8 + 5 \times 7$	$5 \times (7 + 8)$

- 8** A student started a project using a pencil with a length of $7\frac{1}{2}$ inches. After the student completed the project, the pencil had a length of $5\frac{7}{8}$ inches.

How much shorter, in inches, was the pencil after the student completed the project than when the student started the project?

- A** $1\frac{4}{8}$
- B** $1\frac{5}{8}$
- C** $2\frac{3}{8}$
- D** $2\frac{6}{8}$
- 9** What is the value of the following expression?

$$985 \times 23$$

Select one answer.

- A** 4,925
- B** 10,345
- C** 22,655
- D** 23,555

10 Monica has 4 boxes to place in an empty carton.

- The mass of each box is 4.5 kilograms.
- The mass of the carton is 500 **grams**.

What is the total mass, in **grams**, of the carton and the 4 boxes?

Enter your answer in the space provided.

11 Three points are shown in the given coordinate plane.

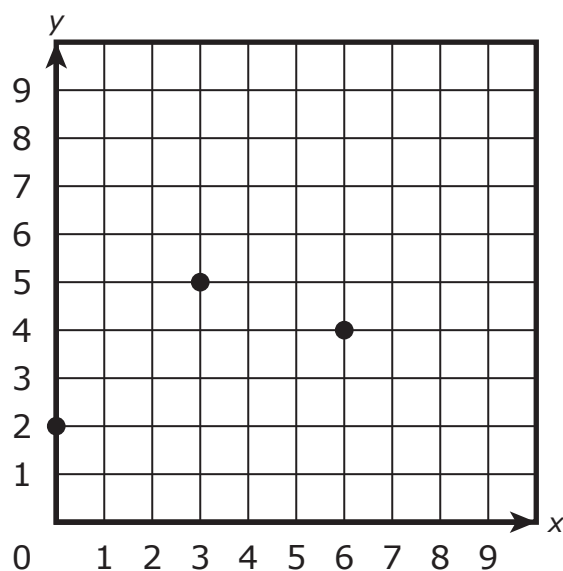

Which **three** pairs of coordinates are the coordinates of the points shown?

Select the **three** correct answers.

- A** (0, 2)
- B** (2, 0)
- C** (3, 5)
- D** (4, 6)
- E** (5, 3)
- F** (6, 4)

- 12** There are 18 students in Ms. Avila’s reading class. Ms. Avila will assign an equal number of pages for each student to read aloud from a book that contains a total of 45 pages.

What is the total number of pages that each student will read aloud?

Select one answer.

A $\frac{2}{5}$

B $2\frac{1}{2}$

C 27

D 63





Section 2 (Calculator)

Directions:

Today, you will take Section 2 of the Grade 5 Mathematics Practice Test. You will be able to use a calculator.

Read each question. Then, follow the directions to answer each question. Mark your answers by completely filling in the circles in your answer document. Do not make any pencil marks outside of the circles. If you need to change an answer, be sure to erase your first answer completely. If a question asks you to show or explain your work, you must do so to receive full credit. Only responses entered within the space provided will be scored.

If you do not know the answer to a question, you may go on to the next question. If you finish early, you may review your answers and any questions you did not answer in this section ONLY. Do not go past the stop sign.



1 A shopper buys some fruit.

- The shopper buys a pack of strawberries and 2 pounds of peaches.
- A pack of strawberries weighs 1.2 pounds and costs \$6.55.
- A pound of peaches costs \$3.29.

Which statement explains the shopper's correct thinking to find the total cost of the fruit?

- A** The shopper thinks that there is 1 pack of strawberries and 1 pound of peaches, and $6.55 + 3.29 = 9.84$.
- B** The shopper thinks that there is 1 pack of strawberries and 2 pounds of peaches, and $6.55 + 2 \times 3.29 = 13.13$.
- C** The shopper thinks that there are 1.2 pounds of strawberries and 1 pound of peaches, and $1.2 \times 6.55 + 3.29 = 11.15$.
- D** The shopper thinks that there are 1.2 pounds of strawberries and 2 pounds of peaches, and $1.2 \times 6.55 + 2 \times 3.29 = 14.44$.

2 Daniel used plastic bricks to build 200 figures in 5 hours.

- He built 60 figures during the first hour and 50 figures during the second hour.
- During the first two hours, he used 3 bricks to build each figure.
- During each additional hour, Daniel used 4 bricks to build each figure.

Which **three** questions can be answered using the given information?

Select the **three** correct answers.

- A** How many figures did Daniel build using 4 bricks?
- B** How many bricks did Daniel use during the fifth hour?
- C** How many bricks did Daniel use during the second hour?
- D** During which hour did Daniel build the greatest number of figures?
- E** What is the total number of bricks Daniel used to build all the figures?



3 A student performed the division problems shown.

$$1875 \div 15 = 125$$

$$3825 \div 15 = 255$$

The student claims that when a 4-digit number ending in 5 is divided by 15, the quotient always ends in 5 and there is no remainder.

Determine whether the student's claim is correct or incorrect. If the claim is correct, explain why it is correct. If the claim is incorrect, give two examples that prove that it is incorrect.

Enter your answer and your work or explanation in the space provided.

4 A teacher is planning a lesson that includes some activities to be completed at a computer.

- There are 18 students in the classroom.
- The students will be split up in groups of the same size.
- Each group will need to use the computer for $\frac{1}{2}$ hour.

Which additional piece of information is needed to determine how long the computer will need to be in the classroom?

- A** the number of students in each group
- B** the number of activities that must be completed at the computer
- C** the number of times the computer will be available in the classroom
- D** no more information is needed to find how much time each group will have



5 Kasey will make as many servings of trail mix as possible with these ingredients: walnuts, pretzels, and apricots.

- Each serving will have $\frac{1}{6}$ cup of walnuts, $\frac{1}{4}$ cup of pretzels, and $\frac{1}{8}$ cup of apricots.
- Kasey has 10 cups of walnuts, 12 cups of pretzels, and 9 cups of apricots with which to make the trail mix.
- Determine how many servings Kasey will make.
- Determine which ingredient Kasey will completely use, **and** determine how much of the other ingredients she will have left over.
- Show your work or explain how you determined your answers.

Enter your answers and your work or explanation in the space provided.

6 A student found the value of the expression $10\frac{1}{4} - 6\frac{7}{8}$.

The student subtracted the whole numbers first and then subtracted the lesser fraction from the greater fraction to find the answer.

Which steps correct the error in the student's thinking?

- A** Step 1: subtract $\frac{2}{8}$ from $\frac{7}{8}$
Step 2: subtract 6 from 10
- B** Step 1: subtract $\frac{7}{8}$ from $\frac{10}{8}$
Step 2: subtract 6 from 10
- C** Step 1: regroup the whole number
Step 2: subtract $\frac{2}{8}$ from $\frac{7}{8}$
Step 3: subtract 6 from 9
- D** Step 1: regroup the whole number
Step 2: subtract $\frac{7}{8}$ from $\frac{10}{8}$
Step 3: subtract 6 from 9



Section 3

(Non-Calculator)

Directions:

Today, you will take Section 3 of the Grade 5 Mathematics Practice Test. You will not be able to use a calculator.

Read each question. Then, follow the directions to answer each question. Mark your answers by completely filling in the circles in your answer document. Do not make any pencil marks outside of the circles. If you need to change an answer, be sure to erase your first answer completely. If a question asks you to show or explain your work, you must do so to receive full credit. Only responses entered within the space provided will be scored.

If you do not know the answer to a question, you may go on to the next question. If you finish early, you may review your answers and any questions you did not answer in this section ONLY. Do not go past the stop sign.

Directions for Completing the Answer Grids

1. Work the problem and find an answer.
2. Write your answer in the boxes at the top of the grid.
3. Print only one number or symbol in each box. Do not leave a blank box in the middle of an answer.
4. Under each box, fill in the circle that matches the number or symbol you wrote above. Make a solid mark that completely fills the circle.
5. Do not fill in a circle under an unused box.
6. Fractions cannot be entered into an answer grid and will not be scored. Enter fractions as decimals.
7. See below for examples on how to correctly complete an answer grid.

EXAMPLES

To answer 632 in a question, fill in the answer grid as shown below.

6	3	2			
<input type="radio"/>	<input type="radio"/>	<input type="radio"/>	<input type="radio"/>	<input type="radio"/>	<input type="radio"/>
0	0	0	0	0	0
1	1	1	1	1	1
2	2	<input checked="" type="radio"/>	2	2	2
3	<input checked="" type="radio"/>	3	3	3	3
4	4	4	4	4	4
5	5	5	5	5	5
<input checked="" type="radio"/>	6	6	6	6	6
7	7	7	7	7	7
8	8	8	8	8	8
9	9	9	9	9	9

To answer .75 in a question, fill in the answer grid as shown below.

.	7	5			
<input checked="" type="radio"/>	<input type="radio"/>	<input type="radio"/>	<input type="radio"/>	<input type="radio"/>	<input type="radio"/>
0	0	0	0	0	0
1	1	1	1	1	1
2	2	2	2	2	2
3	3	3	3	3	3
4	4	4	4	4	4
5	5	<input checked="" type="radio"/>	5	5	5
6	6	6	6	6	6
7	<input checked="" type="radio"/>	7	7	7	7
8	8	8	8	8	8
9	9	9	9	9	9

1 $12\frac{1}{2} - 4\frac{7}{10} = ?$

Select one answer.

A $7\frac{6}{8}$

B $7\frac{8}{10}$

C $8\frac{6}{8}$

D $8\frac{8}{10}$

- 2** A rectangular prism has a length of 20 inches, a width of 10 inches, and a height of 12 inches.

What is the volume, in cubic inches, of the rectangular prism?

Enter your answer in the space provided.

- 3 The following table shows the corresponding terms in two patterns. Both patterns continue to increase using the same addition rule.

Pattern G	3	7	11	15	19
Pattern H	9	13	17	21	25

What is the relationship between corresponding terms in the two patterns?

Select one answer.

- A** Each term in pattern H is 3 times the corresponding term in pattern G.
- B** Each term in pattern H is 6 times the corresponding term in pattern G.
- C** Each term in pattern H is 4 more than the corresponding term in pattern G.
- D** Each term in pattern H is 6 more than the corresponding term in pattern G.
- 4 A package contains $\frac{1}{3}$ pound of deli meat. The meat will be divided evenly among 4 sandwiches.

How much deli meat, in pounds, will be in each sandwich?

- A** $\frac{1}{12}$
- B** $\frac{3}{4}$
- C** $\frac{4}{3}$
- D** $\frac{12}{1}$

5 Which comparison is true?

- A $15.347 > 15.374$
- B $25.502 < 25.52$
- C $35.716 < 35.671$
- D $45.280 > 45.28$

6 The given model can be used to show the solution to a word problem. The shaded counters in the model represent the solution to the word problem.

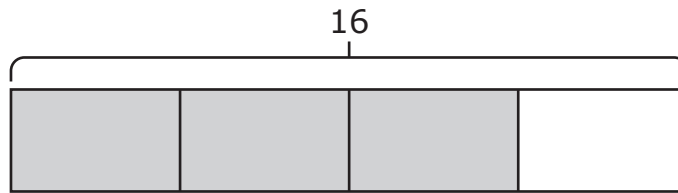

Which word problem can be modeled by the given model?

- A Mike had 12 pennies. He gave Jada $\frac{3}{4}$ of the pennies he had. How many pennies did Mike give Jada?
- B Each of 16 students in a class drank $\frac{4}{3}$ cup of water. How many cups of water did the students drink in all?
- C A group of 16 students went to lunch. Of these students, $\frac{3}{4}$ of them bought milk. How many students bought milk?
- D Mike read 12 pages of a book. Jada read $\frac{4}{3}$ times the number of pages Mike read. How many pages did Jada read?

- 7 The amount of milk needed for each of 5 recipes is shown on the line plot.

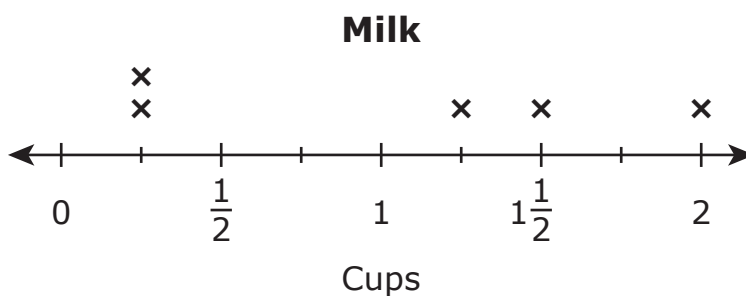

What is the total amount of milk needed for the recipes?

- A** 4
- B** 5
- C** $5\frac{1}{4}$
- D** $5\frac{1}{2}$
- 8 A teacher assigned a project to 5 students. Each student used 3.75 square feet of paper for the project.

What was the total amount of paper used for the project?

Select one answer.

- A** 1.25 square feet
- B** 8.75 square feet
- C** 16.25 square feet
- D** 18.75 square feet

9 What is the value of $7 \div \frac{1}{5}$?

A $\frac{1}{35}$

B $\frac{5}{7}$

C $\frac{7}{5}$

D $\frac{35}{1}$

10 In which number does the digit 8 have a value that is 10 times as great as the value of the digit 8 in the number 456.789?

A 567.894

B 678.945

C 789.456

D 894.567

11 Which set of statements is true?

Select one answer.

- A** All rectangles are quadrilaterals.
All quadrilaterals have 4 sides.
Thus, all rectangles have 4 sides.
- B** All trapezoids are squares.
All squares have sides of equal length.
Thus, all trapezoids have sides of equal length.
- C** All rectangles are trapezoids.
All trapezoids have 4 right angles.
Thus, all rectangles have 4 right angles.
- D** All squares are quadrilaterals.
All quadrilaterals have acute angles.
Thus, all squares have acute angles.





Section 4 (Calculator)

Directions:

Today, you will take Section 4 of the Grade 5 Mathematics Practice Test. You will be able to use a calculator.

Read each question. Then, follow the directions to answer each question. Mark your answers by completely filling in the circles in your answer document. Do not make any pencil marks outside of the circles. If you need to change an answer, be sure to erase your first answer completely. If a question asks you to show or explain your work, you must do so to receive full credit. Only responses entered within the space provided will be scored.

If you do not know the answer to a question, you may go on to the next question. If you finish early, you may review your answers and any questions you did not answer in this section ONLY. Do not go past the stop sign.



Mathematics

1 A contractor measured the length and the width of two rectangular pieces of land.

- The two pieces of land are adjacent and share the same width of 17 yards.
- The first piece of land has a length of $32\frac{1}{3}$ yards.
- The second piece of land has a length of $25\frac{1}{4}$ yards.

Which steps should the contractor use to determine the area, in square yards, of the two pieces of land altogether?

- A** Add $32\frac{1}{3}$ and $25\frac{1}{4}$ and then add the result by 17.
- B** Multiply $32\frac{1}{3}$ and $25\frac{1}{4}$ and then add the result by 17.
- C** Add $32\frac{1}{3}$ and $25\frac{1}{4}$ and then multiply the result by 17.
- D** Multiply $32\frac{1}{3}$ and $25\frac{1}{4}$ and then multiply the result by 17.



2 A student made the following claim.

“If a quadrilateral has two pairs of congruent sides, then the figure is a parallelogram.”

Which **two** figures can be used to show that the student’s claim is incorrect?

Select the **two** correct answers.

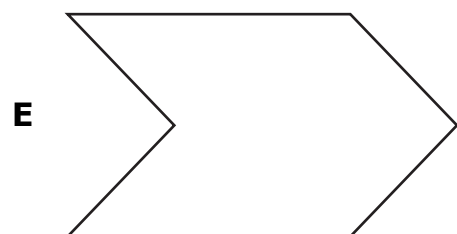
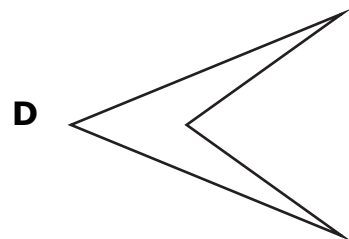
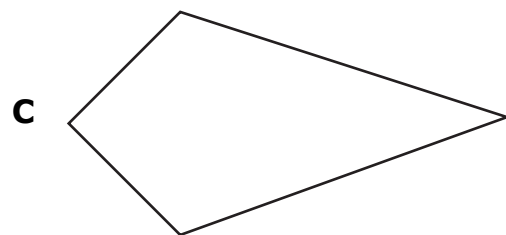
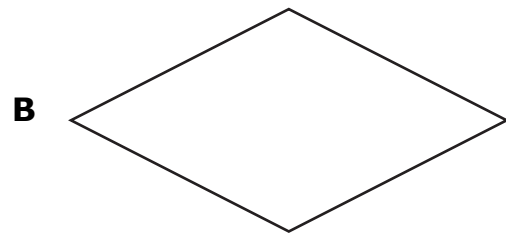
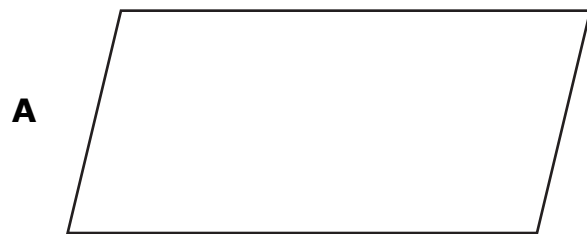



Mathematics

- 3 Bernard stacked two gift boxes that are each in the shape of a right rectangular prism. The dimensions of the resulting shape are shown.

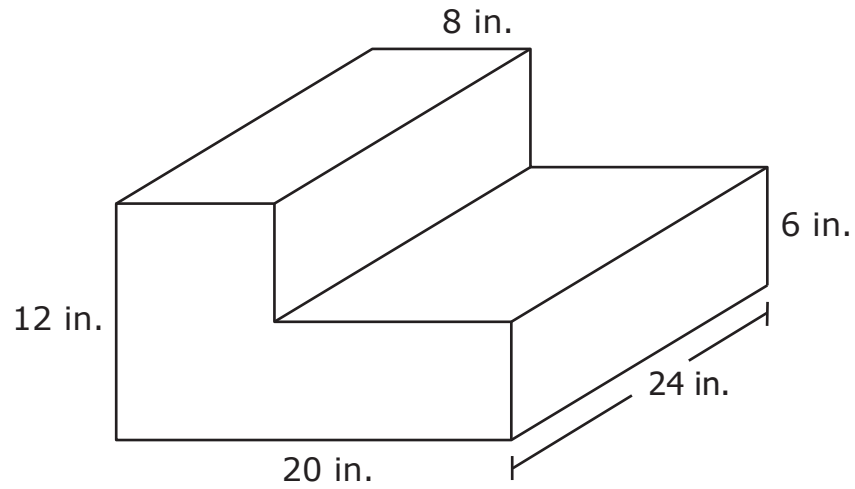

What is the total volume, in cubic inches, of the gift boxes?

Enter your answer, and your work or explanation in the space provided.



- 4 An artist is using a squared wooden panel to create a piece of art. The panel is divided in smaller squares as shown.

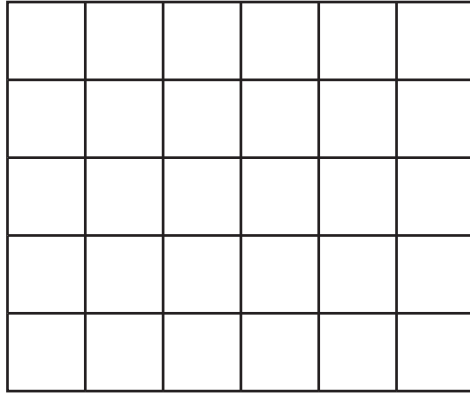

The artist paints $\frac{3}{5}$ of the squares in red, then draws golden circles on $\frac{1}{3}$ of the painted squares to decorate it.

The artist draws the model shown to represent the fraction of the whole wooden panel that is both painted and decorated.

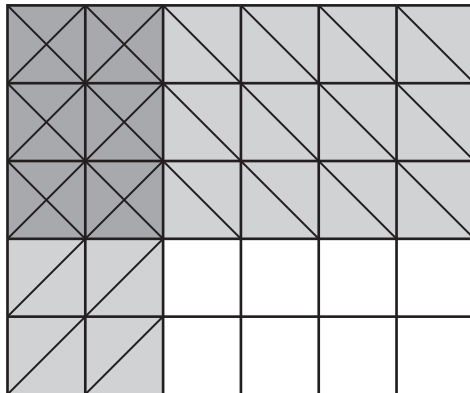

Which statement is true about the model the artist drew?

- A The model is correct because it represents the equation $\frac{3}{5} + \frac{2}{6} = \frac{6}{30}$.
- B The model is correct because it represents the equation $\frac{3}{5} \times \frac{1}{3} = \frac{1}{5}$ and $\frac{1}{5}$ of 30 is 6.
- C The model is incorrect because 2 of the 6 columns are shaded and there should be 3 columns with 1 column shaded.
- D The model is incorrect because $\frac{3}{5} \times \frac{1}{3} = \frac{1}{5}$ and $\frac{1}{5}$ of the model can only be represented by shading 1 row of squares.



5 A teacher needs to buy batteries for 32 calculators.

- There are 20 basic calculators that each require 3 batteries.
- There are 12 advanced calculators that each require 4 batteries.
- The batteries are sold in packages of 24.

The teacher thinks that 6 packages of batteries will be needed and that there will be 12 batteries left over after the calculators are filled.

Provide a solution path that shows whether the teacher is correct or incorrect. Explain what each step in the solution path represents in terms of the situation.

Enter your answer and your work or explanation in the space provided.

6 During a 5-day paper recycling drive, the students in a classroom collected 12.4 pounds of paper each day for 4 days and 8.39 pounds of paper on the fifth day.

Which steps can be used to find the total number of pounds of paper the students collected for the recycling drive?

- A** Multiply 12.4 by 4, then add 8.39.
- B** Multiply 12.4 by 5, then add 8.39.
- C** Add 12.4 and 8.39, then multiply the result by 4.
- D** Add 12.4 and 8.39, then multiply the result by 5.





STERLING



WE
GOT
NOW



MANE



WE
GOT
NOW



SAKA



WE
GOT
NOW

